

Rocket Kiln Plans, Design and Materials

Revised April 16, 2026

Lisa Orr and Andrew Linderman

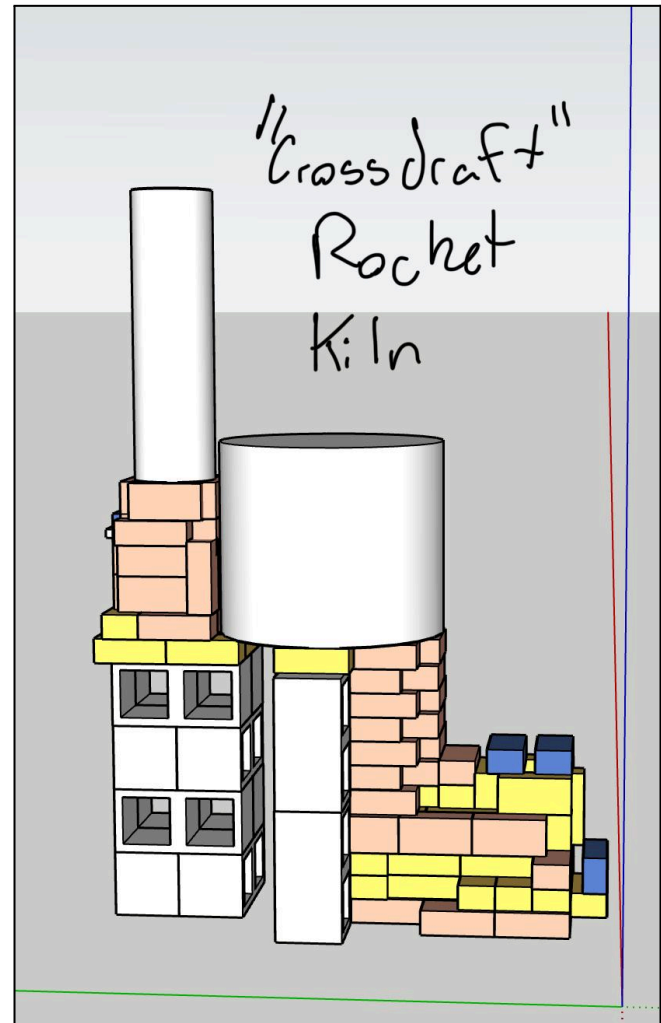
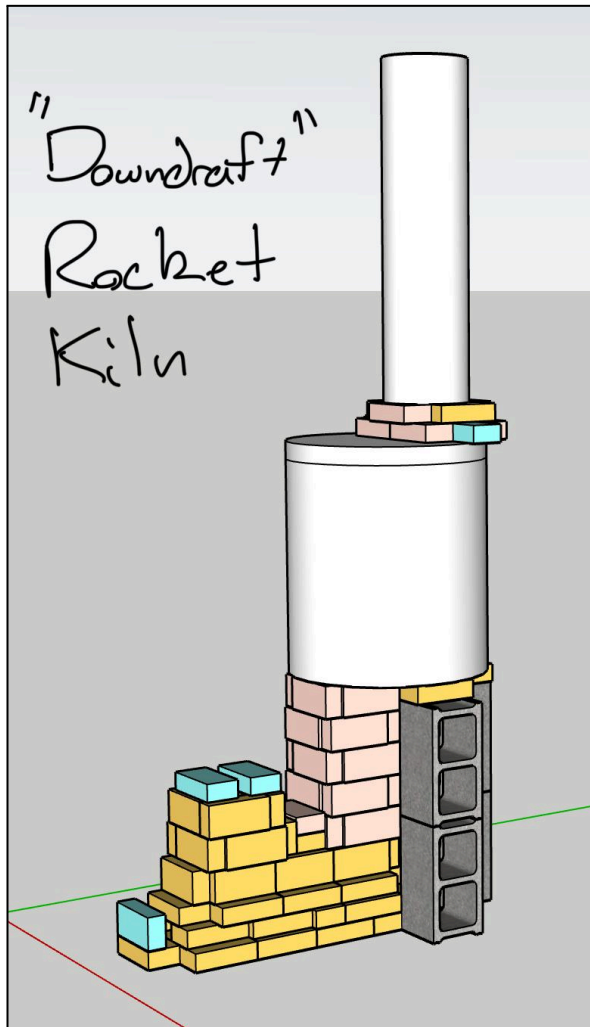

This is a "Living" Document and will be updated as new designs, methods, and revisions are made.

Team Rocket Kiln:

Lisa Orr, Designer, rocket kiln guru: lkoceramics@gmail.com

Chris Alveshere: chrisalveshere.com

Simon Levin, sketchup renderings burndirt@gmail.com

Andrew Linderman, sketchup and development: alindermanpottery@gmail.com

Rodney Morgan, Technical Advisor: rodneymorgan@hotmail.com

Chris McClellan, aka Uncle Mud, Technical Advisor: industrialrustic@gmail.com

Additional information can be found at:

Lisa Orr's Website, Links to (plans/info)

<https://lisaorr.com/projects/>

Wood Fired Rocket Kiln Facebook Group:

<https://www.facebook.com/groups/612205583636245>

Andrew Linderman's Website (plans and info)

<https://www.lindermanpottery.com/links>

Overview

This document outlines the construction and firing for both a “downdraft” and “crossdraft” version of the rocket kiln, and provides plans on how to construct a “brick efficient” and “firing efficient” version of the rocket engine (J-tube).

Why build a rocket kiln?

Rocket kilns are a cost-efficient, time-efficient, fuel-efficient and environmentally conscientious way to fire ceramics. The designs are virtually smokeless; which is great for health and environmental reasons, as well as allows rocket-style kilns to be fired in urban areas. Most are affordably assembled from upcycled kilns and bricks. These kilns are great for experimenting at various temperatures, can be fired in oxidation or reduction, and while they do not impart heavy wood-ash, they can be soda-fired for flash effects.

The “Downdraft” Rocket Kiln

This design is great if you need a semi-portable kiln. This design can easily pack up and fit in the back of a truck, SUV, or wagon. We recommend using this design if your kiln needs to be disassembled between firings or moved. The main downsides to this design are the reduced stacking volume and the need to remove the chimney to load/unload the kiln.

The “Crossdraft” Rocket Kiln

This design is our preferred design for permanent installations. While this design requires more bricks, cinder blocks, and space; it remedies the two downsides of the downdraft version. The entire kiln body can be used to stack work, and the chimney is stationary.

Which J-Tube or Rocket Engine should I use?

This document provides plans for a “brick-efficient” and “firing-efficient” rocket engine. The “brick-efficient” plan uses the least number of bricks and theoretically requires zero brick cutting. This is great for temporary or portable kilns or can be a great solution as you’re sourcing more kiln materials. The “firing-efficient” plan uses more bricks (especially soft bricks), cinder blocks, and materials as a whole, but will result in a more insulated and easy-to-fire (fire faster) kiln. Neither plan needs to be followed explicitly, but the proportions of the J-tube and chimney (especially the cross-sectional area) should be adhered to. All of these considerations will be discussed in far more detail as the plans are outlined below.

Materials and Tools

***note: specific material counts are based on the depicted plans and Lisa and Andrew's kilns. Actual materials used will likely vary from kiln-to-kiln. "CDFE" refers to the cross draft, firing-efficient plan and "DDBE" refers to the downdraft, brick-efficient plan.

Materials List:

Hard Brick: (9x4.5x3") For CDFE, 42 (4 extra for covering the Primary and Secondary Air, and 2-3 for the bag wall) No cuts needed but a few soaps or half bricks can be handy. For DDBE 63 hard bricks are needed.

Soft Brick: (9x4.5x3") 74 for CDFE or 29 for DDBE.

Concrete Block: 12 (8"x8"x16" blocks) for CDFE and 6 for DDBE.

Insulated Stove Pipe Chimney: 1: 8" int. Diameter. 4' length. Tuning the kiln by changing height of chimney is important depending on the size of the ware chamber.

https://www.amazon.com/AlIFuelHST-Double-Wall-Chimney-Pipe/dp/B09HJDKMJ8/ref=pd_bxgy_thbs_d_scc1/1/137-4419564-0162100?pd_rd_w=IYDhk&content-id=amzn1.sym.de9a1315-b9df-4c24-863c-7afcb2e4cc0a&pf_rd_p=de9a1315-b9df-4c24-863c-7afcb2e4cc0a&pf_rd_r=Z3W7711QP69CNRN57WVJ&pd_rd_wg=2asEa&pd_rd_r=67ff61cc-2c62-442e-8661-462aa068e02c&pd_rd_i=B09HJDKMJ8&psc=1

Alternatively, one can be made out of 2 coils of kaowool inside a 4' cage or assembled out of softbrick.

Kaowool Blanket: (Not shown in Sketchup models) about 1'x4' is needed. Additionally, a ~2'x5' roll can be wrapped around the heat riser to reduce cold air inlet and increase insulation (faster firing!).

Firebox Grate: a 9x7" piece of perforated kiln shelf with "swiss cheese" holes drilled into it. 1/3"-1/2" holes are ideal, about 20 of them, with no running seams. Scatter them randomly.

Kiln Body: 1. We used a 1018 or 1027 kiln body (10-sided kiln with 2 or 3 rings), other sizes of kiln will also work. The bottom will get a ~7"x7" square hole next to the side wall. For the CDFE, the back of the body will also get a ~7"x7" hole. The DDBE, will get a ~5x10 hole cut in the lid. Important to add worm band an old kiln tops and bottom rings for structure, the body may need to be banded as well if its metal jacket has corrosion.

Kiln Shelves: 4-6: a variety of old kiln and broken shelves have worked great for us. We used some small pieces to shim around the concrete block supports, made one into a perforated kilnshelf acting as a grate (7"x9" with 1/2" holes drilled all over it), 3-4 inside the kiln, and 1 kilnshelf damper to close the flue at the end of the firing approx 9" w x13" long. For the DDBE plans, 2-3 rectangular shelves (10"x20" are ideal) will also be needed for the chimney partition inside of the kiln.

Kiln Furniture: we used regular mullite stilts from an electric kiln or cut hardbrick, dipped in thin zircopax kiln wash for soda.

Worm Band (extremely long **hose clamp** material): 1-2 35' packages or 1- 50' package. This wrapped around various parts of the kiln to hold the bricks together.

https://www.amazon.com/STEELSOFT-Assortment-Fasteners-Stainless-Adjustable/dp/B08Y6LKW5F/ref=asc_df_B08Y6LKW5F/?tag=hyprod-20&linkCode=df0&hvadid=507467648565&hvpos=&hvnetw=g&hvrand=4126750598964101978&hvpone=&hvptwo=&hvgmt=&hvdev=c&hvdvcmld=&hvlocint=&hvlocphy=9001812&hvtargid=pla-1266000177756&th=1

Kiln Wash: Not necessary unless you are spraying soda or using soda. We used an 85:15 mixture of zircopax:kaolin and BRUSHED it on. Mix thinly like skim milk.

Notes on insulation: Having as much of the kiln insulated as possible is ideal. The heat riser MUST be made of soft brick. Some of the soft brick around the base of the kiln could be replaced with Kaowool, several layers of ceramic board, a cob/perlite mixture, or some combination of those. Filling up cracks in the heat riser and kiln with a refractory clay slurry or castable is helpful to prevent drafts.

<https://ceramicartsnetwork.or/ceramic-recipes/recipe/Castable-Refractory-168843#>

Tools List:

Kindling Cracker, Fiskars x11, or similar: The Kindling Cracker is an extremely safe wood splitter that anyone can use. No axe necessary for the splitting needed for this kiln. Lisa considers this a necessity as extremely thin sticks are required for this type of kiln, and almost anyone can help split wood finely without axe experience. Andrew uses a Fiskars x11, which is a splitting axe with a short, 17" handle, giving you a lot of control to split smaller kindling.

https://www.northerntool.com/products/kindling-cracker-king-firewood-kindling-splitter-xl-size-118995?cm_mmc=Google-pla&utm_source=Google_PLA&utm_medium=Logging%20%3E%20Wedges&utm_campaign=Kindling%20Cracker&utm_content=118995&ogmap=SHP%7CPLA%7CGOOG%7CSTND%7Cc%7CSITEWIDE%7C OOT%7C%7C%7C%7C168839876%7C8722150916&gad_source=1&gclid=CjwKCAjw1NK4BhAwEiwAVUHP UEEkCtUupgTo29M1NVsktYNbcf6brNWBB1r1JcmFLILFZQbhc2afOBoCtYYQAvD_BwE&gclsrc=aw.ds

Mallet or hammer to split wood (with kindling cracker)

Pyrometer and thermocouple (6"-8") to measure rise of temp

Cones to measure heat work

Stepladder to load and unload kiln

Soda Sprayer if going to apply soda, OR **small pinch pots** made from scrap high fire clay to place soda recipe chunks into

https://www.vevor.com/stainless-steel-sprayer-c_10177/1-5-gal-industrial-contractor-stainless-steel-concrete-sprayer-garden-p_010699118223?adp=gmc&utm_source=google&utm_medium=cpc&utm_id=12662136951&ad_group=120277860237&ad_id=511500383956&utm_term=&gad_source=1&gclid=CjwKCAjw1NK4BhAwEiwAVUHPUBNr8FXuFKjq07r870pyZX4_1Ub_G5TfbT-jxGGhRX20VGN0JHutxoCAw0QAvD_BwE

Angle grinder with metal cutting blade + masonry cutting blade (if no tile or brick saw), or universal cutting blade or all materials

Drill with large regular drill bit (1/2") PLUS 3/8" or 1/2" masonry bit for perforating kiln shelf, +spray bottle when drilling kiln shelves

https://www.amazon.com/Diamond-Ceramic-Porcelain-Granite-Bottles/dp/B0B24RXXDJ/ref=asc_df_B0B24RXXDJ?mcid=ad606b364d4b36d1a0ddf33c2845dd81&tag=hyprod-20&linkCode=df0&hvadid=693675076965&hvpone=&hvnetw=g&hvrnd=2929751185481748477&hvptwo=&hvgmt=&hvdev=c&hvdvcmdl=&hvlocint=&hvlocphy=9001812&hvtargid=pla-1679943505438&hvocijid=2929751185481748477-B0B24RXXDJ-&hvexpn=0&th=1

Small handsaw or saber saw for cutting soft brick. Sheetrock saws or keyhole saws work really well.

Level to ensure that the foundation is flat. Both a small 6-9" "torpedo" level and 2'-4' levels would be helpful.

Screwdrivers flathead and phillips for taking old electric boxes and wires off of kiln shell

Scissors (or box cutter) for cutting kaowool

Tin snips or similar for cutting worm band

Tile saw (makes cutting kiln shelves really easy). A diamond wheel on an angle grinder is a cost-effective substitute if you only need to make a few cuts.

Large magic marker to mark cuts, etc

Handy but not necessary:

Drill Press (makes it easier to perforate kiln shelf)

Brick saw. (same as tile saw)

Insulation Knife/Saw: serrated knife great for cutting kaowool.

Some items to taken into consideration:

1. K26 is a good soft brick. The K23 is softer but also works well. 2600degF or 3000degF brick.
2. High-Temp Fiberboard and Kaowool are great options to increase insulation in hard to reach areas of the kiln, or if you don't have access to a brick saw.

The “Rocket Engine” or What’s Below the Kiln

This diagram shows the rough layout and proportions of the parts of the rocket kiln. The proportions of the J tube, heat riser and flue openings are important for the efficient firing of a rocket kiln. This is designed to fire in neutral/oxidation.

An 8” insulated/double wall stove pipe has a cross-sectional area roughly equivalent to a 7”x7” square opening. If you are building this from recycled brick/materials, maintaining a ~50 sq.in. area throughout the J Tube, is important for proper combustion and draft to take place.

J Tube Proportions:

1:2-:3+

A taller heat riser has been helpful for fast, even firing, but will raise the height of your kiln, possibly making it more difficult to load.

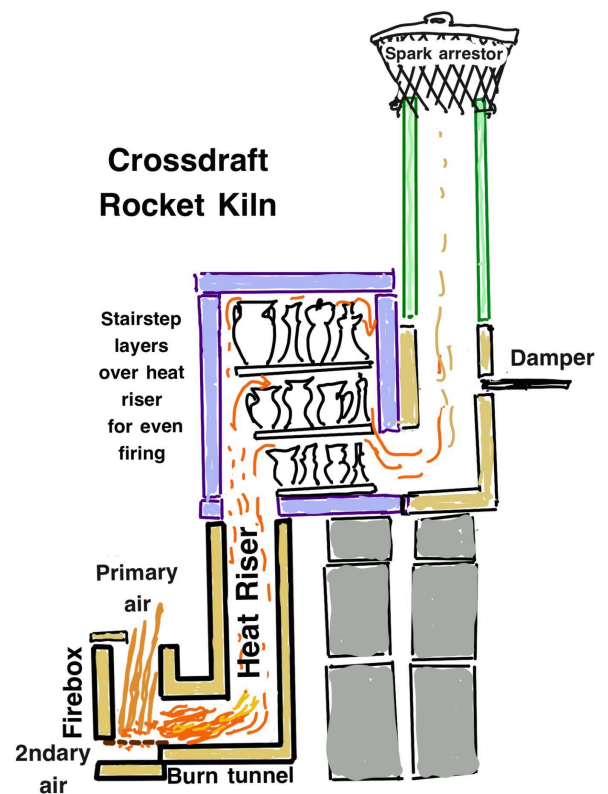
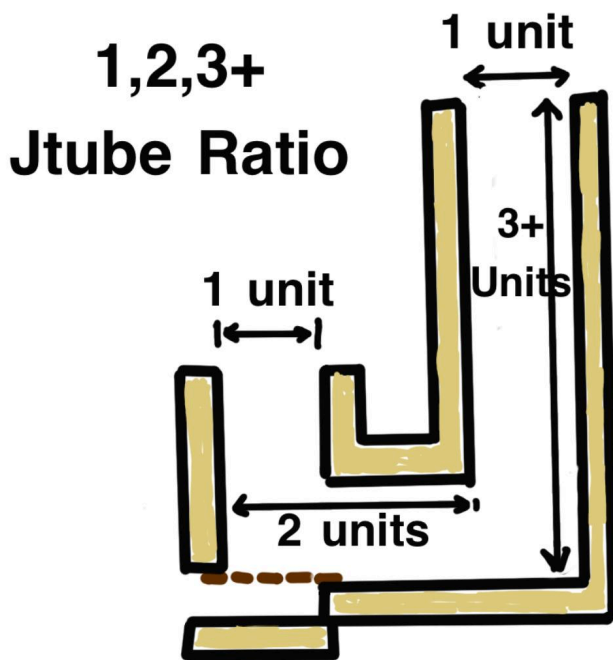

A note about the Sketchup renderings:

Yellow bricks are Hard Bricks.

Pink/Salmon bricks are soft bricks.

Blue bricks are moved throughout the firing, and can be hard or soft. Any of the bricks located around the damper should be soft bricks.

Kaowool is NOT denoted in Sketchup. A 1027 Kiln body was used in the renderings, but many other size kiln shells will also work well.

The numbered layers of the two J-Tube designs are directly comparable.

You are encouraged to use the bits from either/both design that work best for the materials you have available and what you need out from the kiln.

Layer-By-Layer Plans: Brick Efficient J-Tube (DDBE)

Layer 1

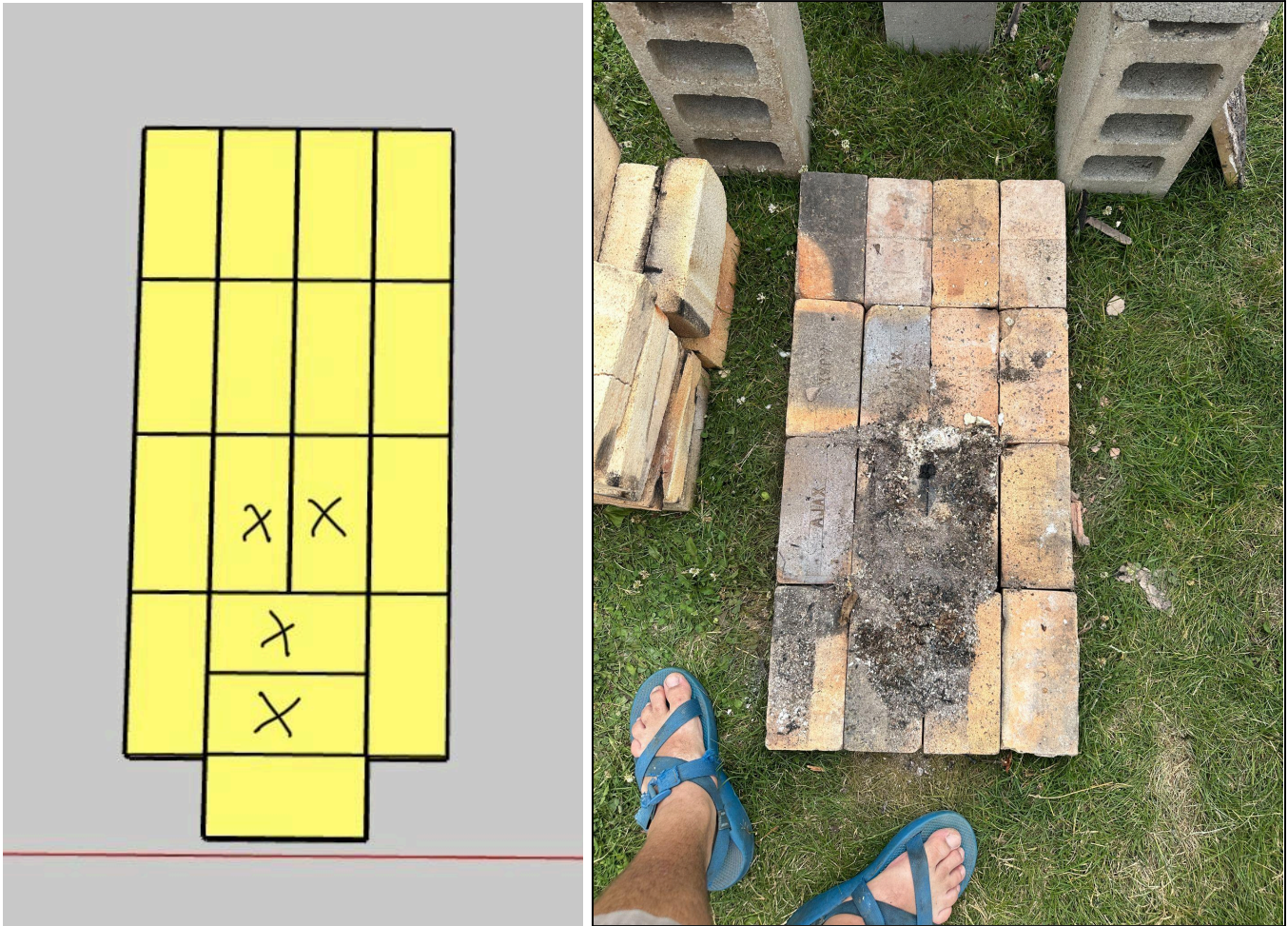

Make sure you have a level area to construct the kiln. Packed gravel works well, if you don't have a concrete/asphalt/paved surface. Or build on a leveled layer of concrete pavers. Hardi Backer or Cement board also make a good underlayment base.

Only the brick under the grate/firebox need to be hardbrick, the rest can be soft brick (see "x" in rendering). The plan uses hard brick because it is typically easier to source. Upcycled, broken, or imperfect soft brick can be used here as the goal is to keep heat from reaching the ground that this is constructed on.

The footprint of J-tube measures 18" x 40.5".

Layer 2

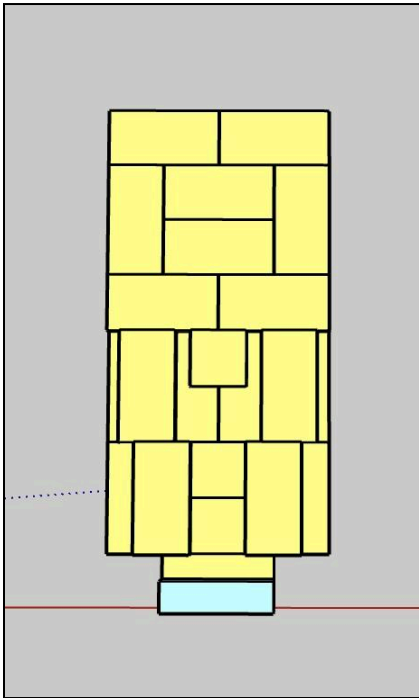

The half brick can be replaced with full bricks as seen in the CDFE plans. The grate rests on the half brick and bottom most bricks. The spacing of the two bottom bricks (Secondary air opening) must be at least 4.5" so you can close up the kiln at the end of the firing. The opening should be as wide as possible.

Layer 3

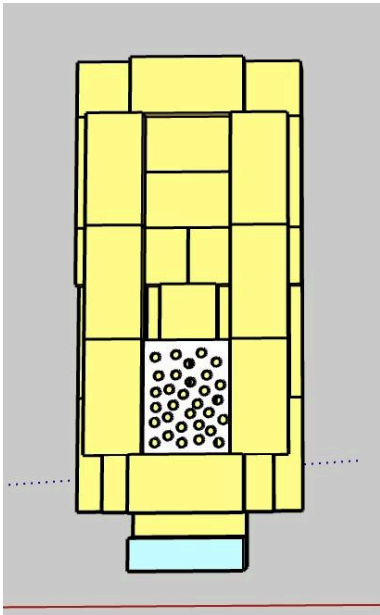

The grate should measure 9" x 7" and fit snugly.

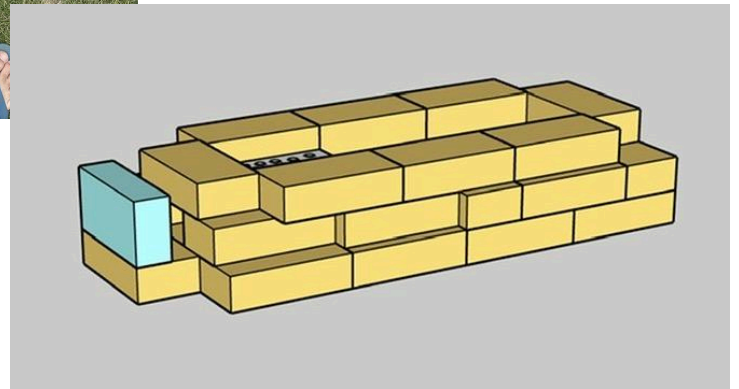

Layer 4

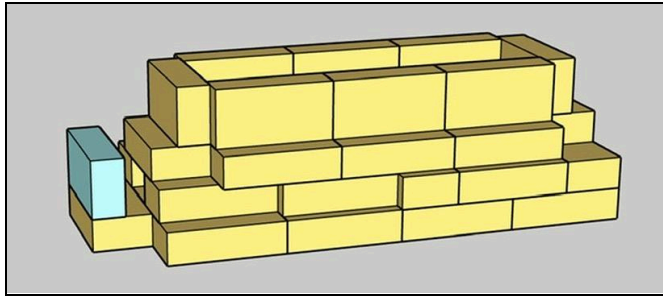
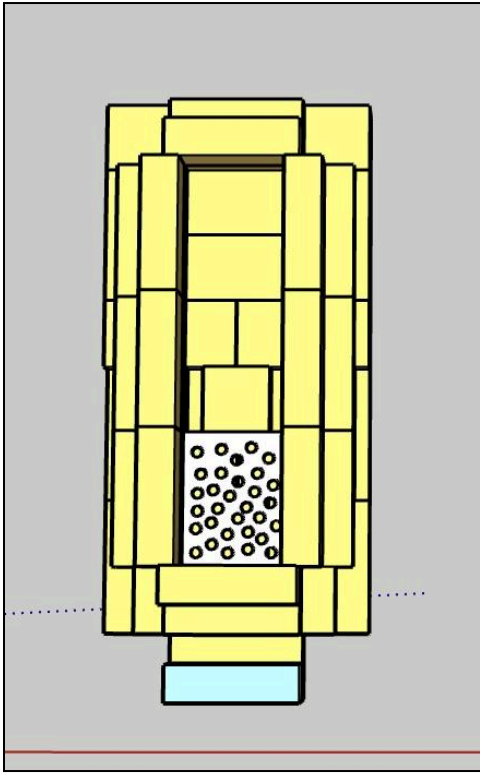

Layer 5

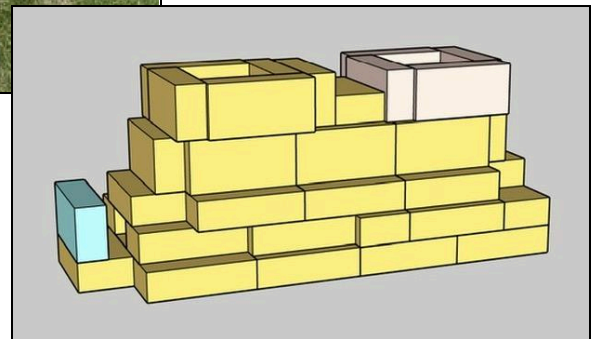
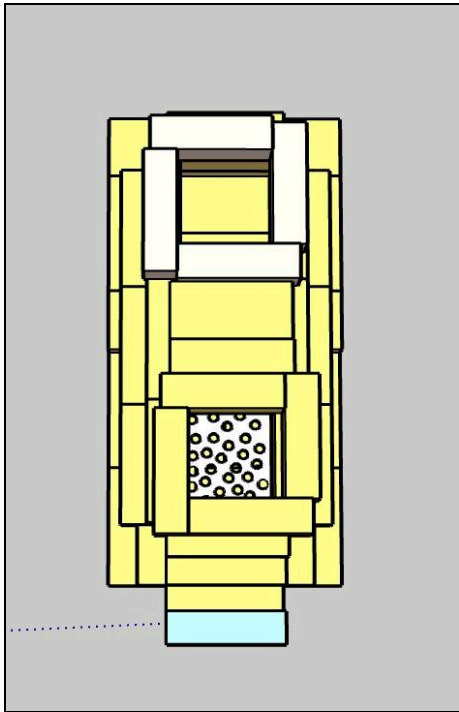

As you will see in later pictures, it is recommended to drape a piece of kaowool over the burn tunnel. You could also add a soft brick as seen in Layer 6.

Layer 6

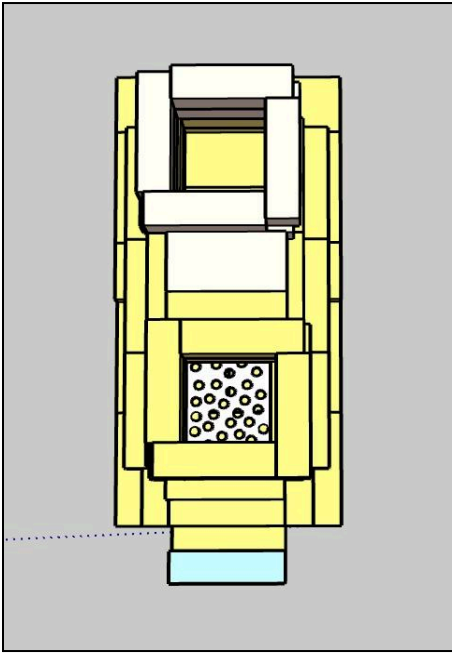

Layer 7 & 8

These layers complete the heat riser to finish the "J-Tube" or Rocket Engine.

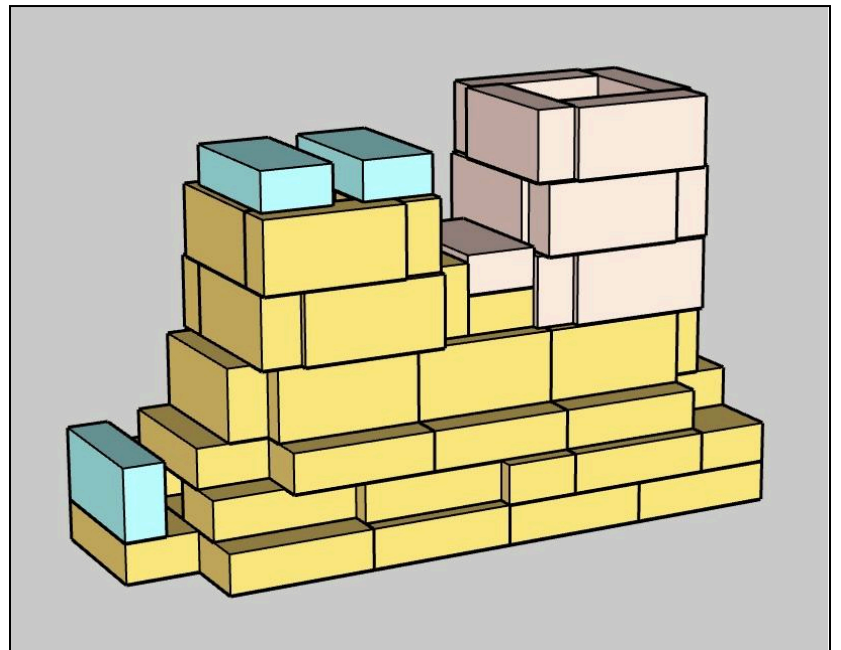

Finished "Brick-Efficient" J-Tube

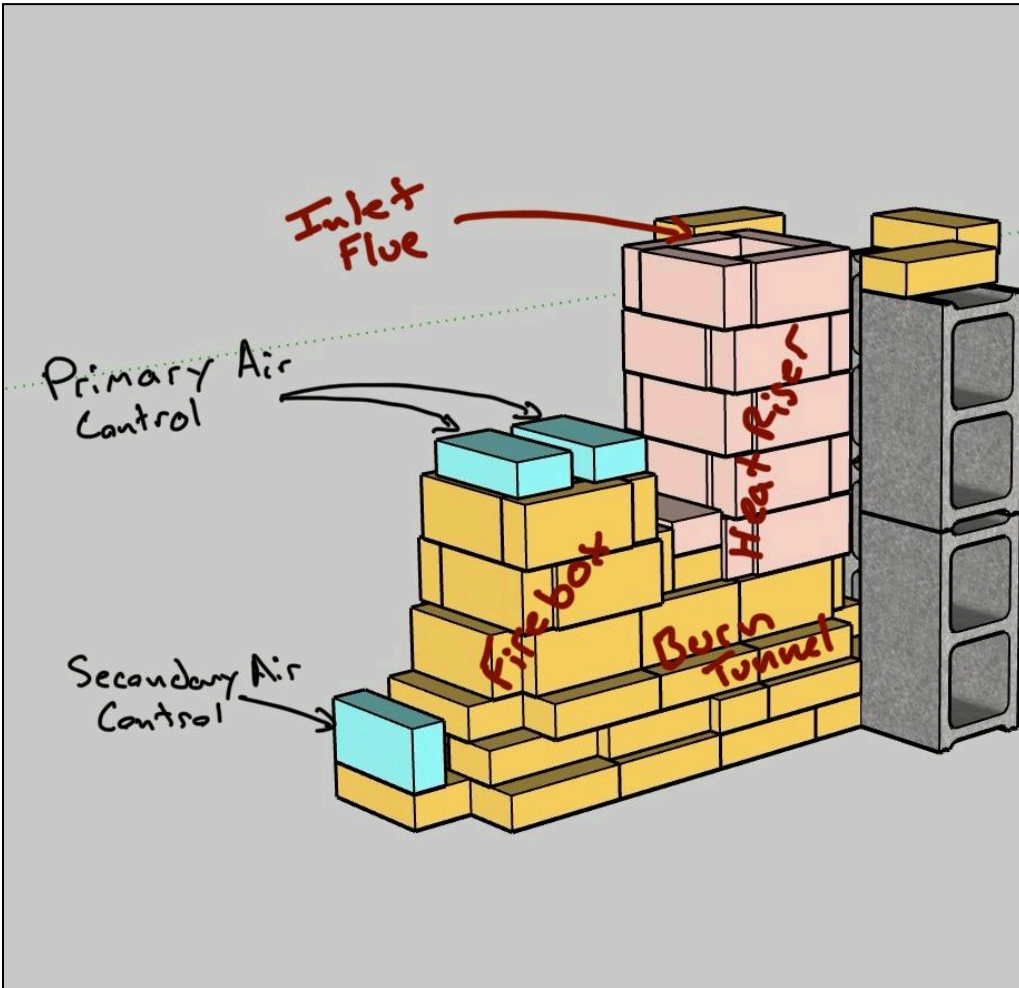

Layer-By-Layer Plans: “Firing-Efficient” J-Tube (CDFE)

Layer 1

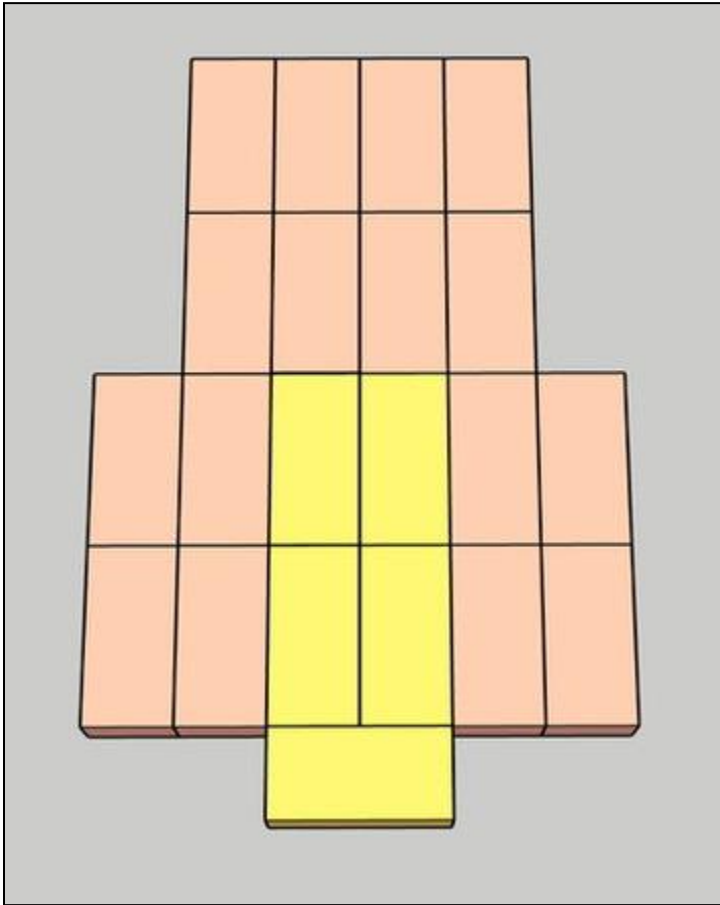

The foot print of the J-Tube measures 27" x 40.5".

Make sure you have a level area to construct the kiln. Packed gravel works well, if you don't have a concrete/asphalt/paved surface. Or build on a leveled layer of concrete pavers.

The hard bricks will be located underneath the firebox/grate.

Upcycled, broken, or imperfect soft brick can be used here as the goal is to keep heat from reaching the ground that this is constructed on.

Layer 2

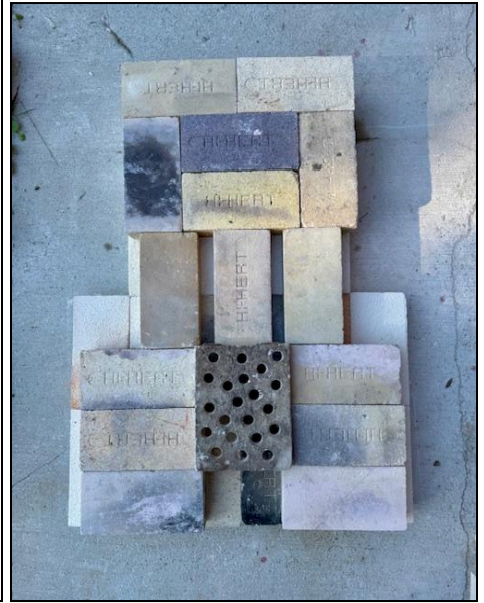
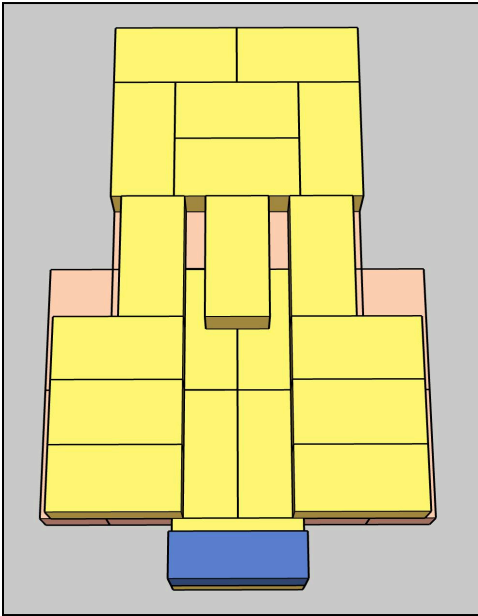

The opening for the secondary air (bottom two bricks) should be as large as possible.

Layer 3

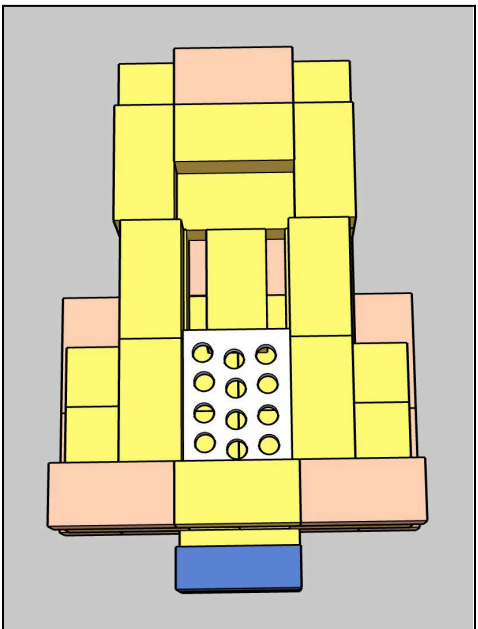

The "Swiss Cheese" Grate measures 9" x 7".
The rendering shows ~1" holes, but more small ($\frac{3}{8}$ " - $\frac{1}{2}$ ") holes work better.
The grate should fit snugly to the front, left and right of the firebox.
The blue brick will be used to adjust the secondary air and seal the kiln at the end of the firing.

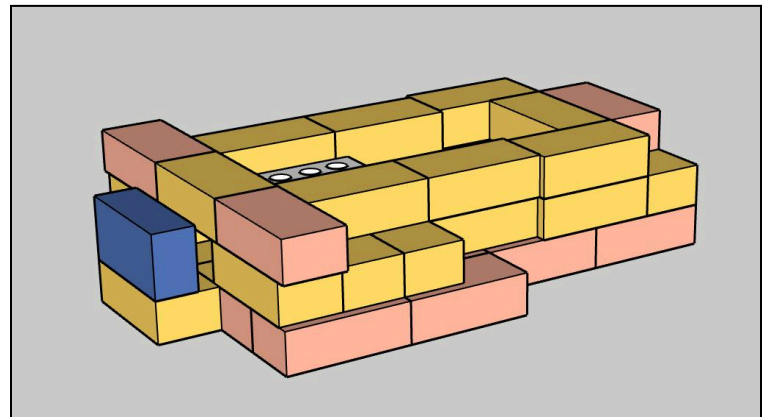

Layer 4

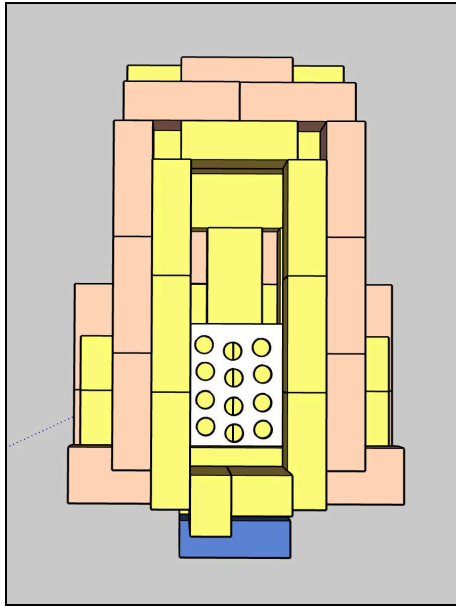
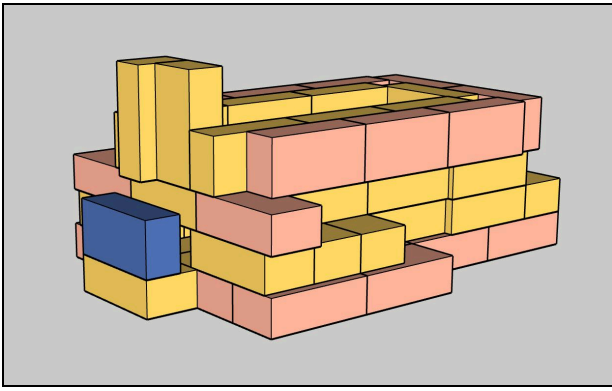

The void space in the back corners (bottom of heat riser), should be filled with kaowool or an insulating cob mix/castable. If you have extra soft bricks you can cut some to fill in the spaces.

The vertical bricks in the front of the firebox could be cut to fit. We wanted to make plans that excluded any hard brick cutting, but if you have a soap brick, that could be used instead. Soft brick should not be used in the firebox or anywhere that has wood/brick hitting one another.

This entire layer could have a worm band wrapped around it to keep everything snug and reduce air leaking into the burn tunnel and slowing the draft. If you plan to cover the entire bottom section/J tube with insulating castable, skip this worm band.

Layer 5

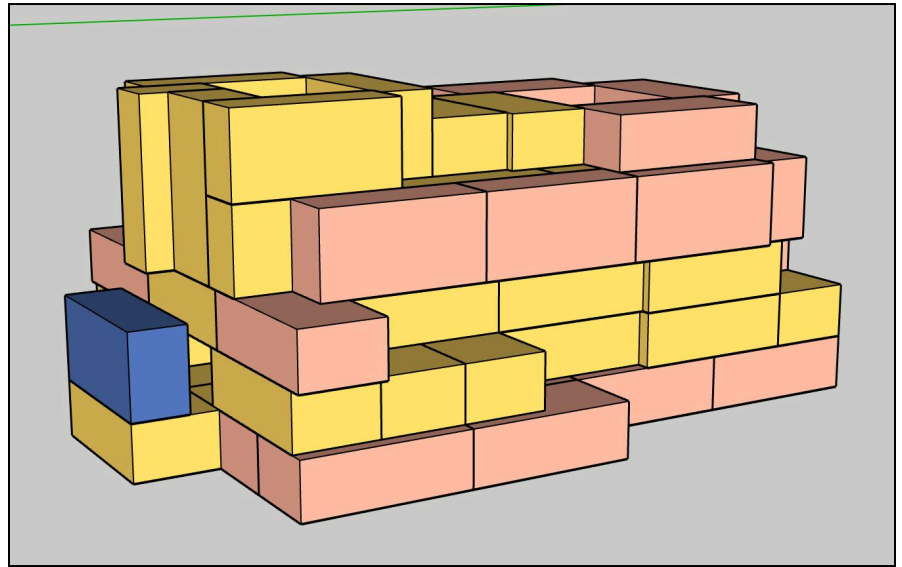
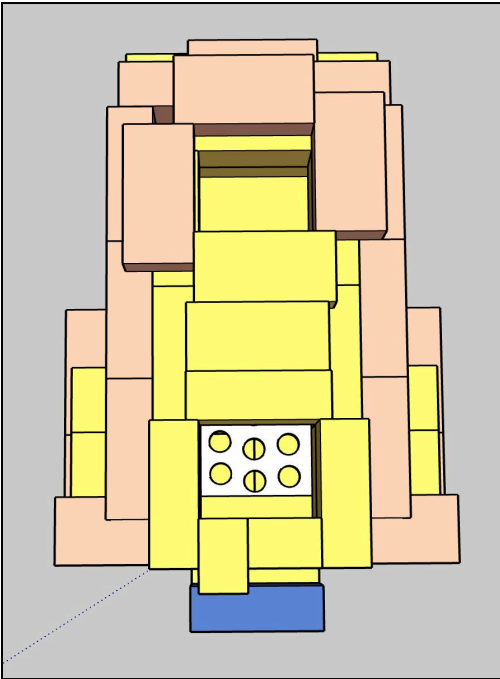

The top Layer of the firebox could be wrapped with a metal strap or long hose clamp type band to add strength to the upright bricks. When stoking, the wood will lean against the top edges and can force the bricks to separate if they are not braced.

Kaowool or soft brick (see layer 6) can be placed over the top of the burn tunnel to increase the insulation there, or if you are stuck firing with damp wood, this is a great place to quickly dry it out before dropping it into the firebox. Firing with wet or damp wood will stall a firing. Please note how the bricks starting the heat riser are offset counter clockwise. They will alternate (see layer 6-11) as you build the heat riser taller. As shown in the photo to the right, the heat riser jogs to one side slightly, this allows the spanned bricks to be supported by the layer below.



Layer 6

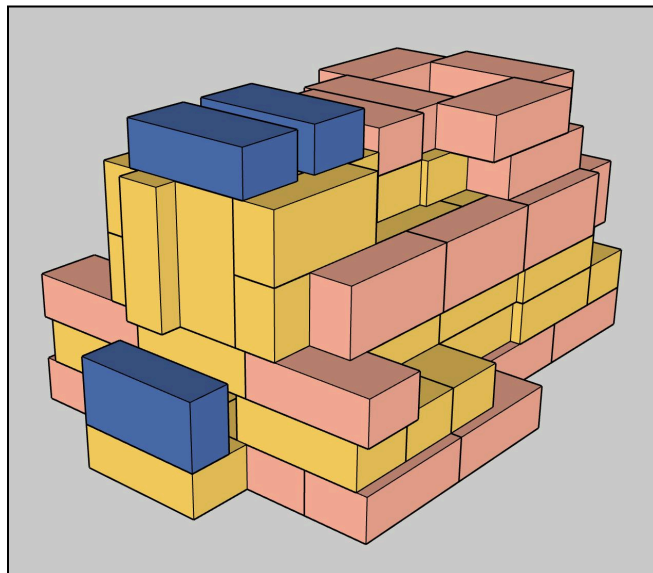

Layers 7-11

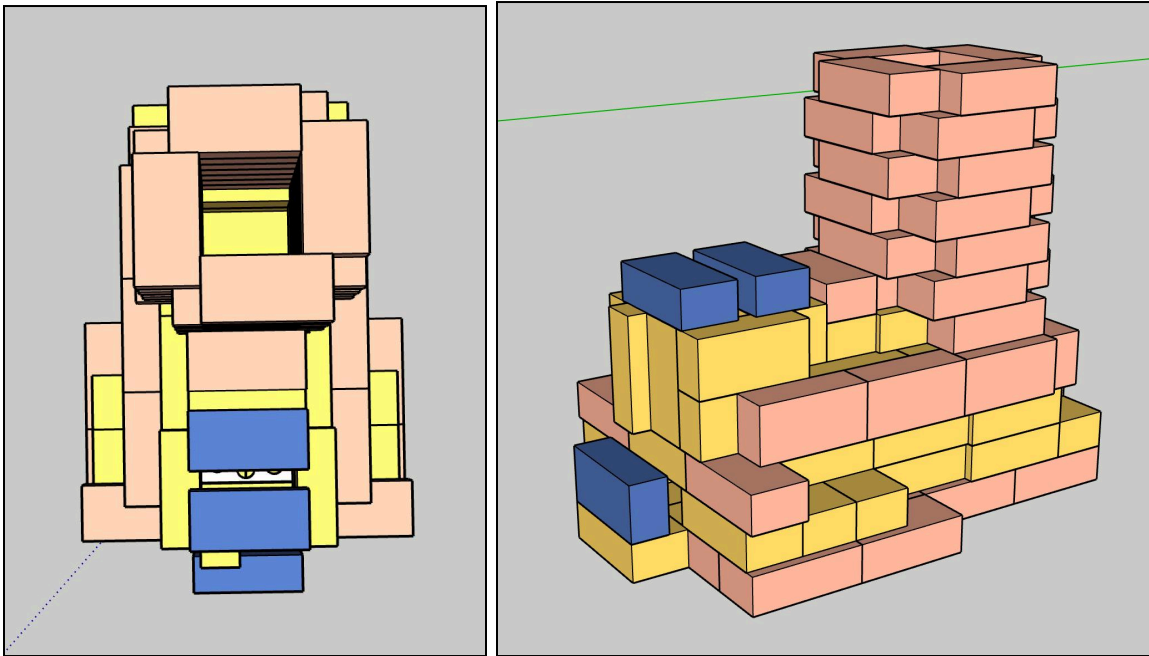

In this step you will finish building the heat riser. In this model, the heat riser has 7 total soft brick layers. If you are using different dimensioned bricks, you may need more (or fewer) layers. The height from the bottom of the J tube (measured internally) to the top of the heat riser should be about 27". We have made kilns with shorter heat risers, but they burn less efficiently and fire less evenly.

Finished "Firing-Efficient" Rocket Kiln



Extended Grate Option: Layer 2 and 3 adjustments

We have found that extending the grate further into the burn tunnel can help alleviate some of the coal bed buildup that may choke the airflow through the J-tube. This is still an experimental adjustment and has had some great results (Lisa has fired one to Cone 10 in ~2.5 hrs with this adjustment), but this improvement has caused slower firing times in other rocket kilns. If you are having problems with a large coal bed that is clogging your burn tunnel, this is an adjustment you may want to make. We are not yet recommending implementing this change right away as we are still testing various grate dimensions. But have found that around 10-14" seems to work well.

The below figures show the removal of a few bricks in Layers 2 & 3 to accommodate a longer grate. If this is something you plan to incorporate into your rocket kiln build, you may want to try a grate length that is somewhere between a single and double.

DDBE Extended Grate Layout

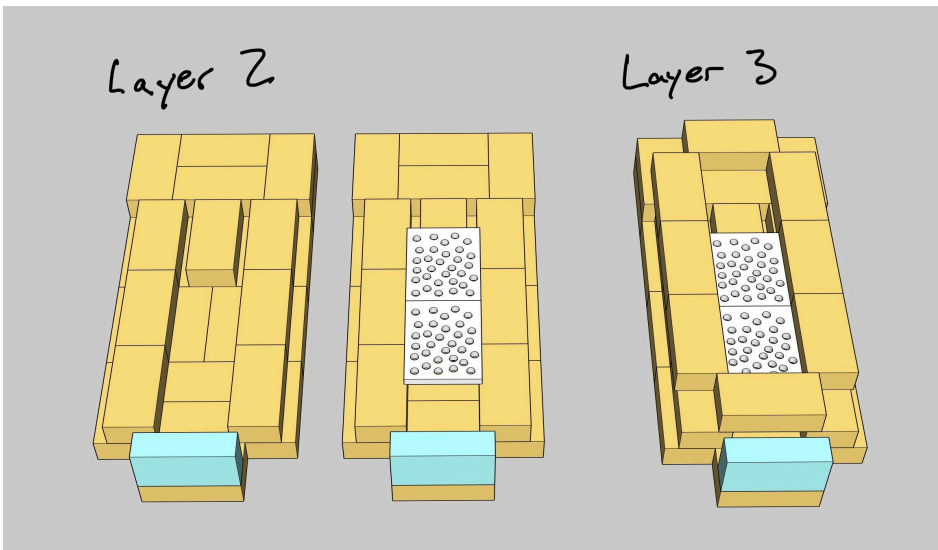

CDFE Extended Grate Layout

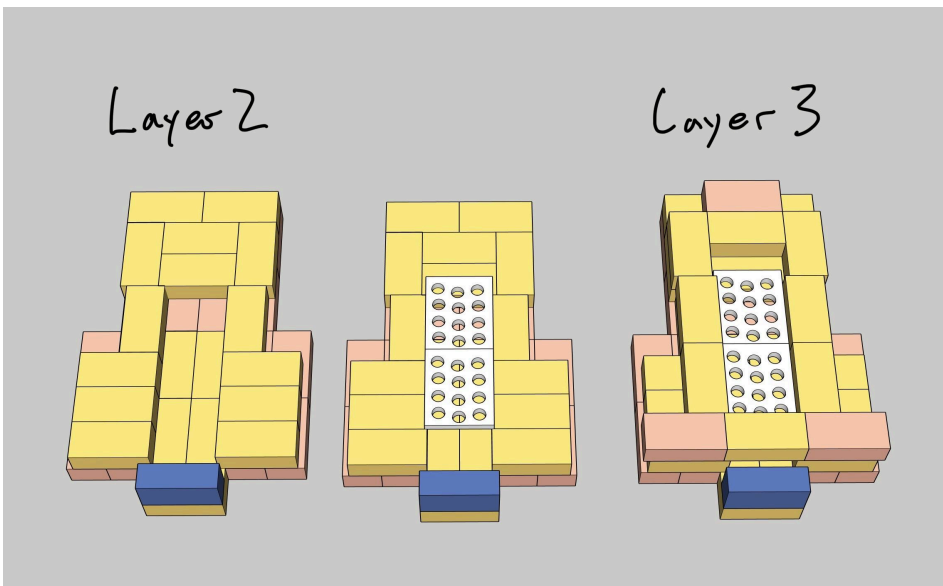

The Ware Chamber or Kiln Body

Placing the Supports

Here you will be adding the cinder block supports for the kiln (and chimney for the CDFE plans). You may want to wrap the entire heat riser with a 2'x5' kaowool blanket before placing supports. You may need shims (pieces of broken kiln shelf) and a kaowool gasket around the heat riser before placing the kiln body. For the Cross Draft version, you may want to use a large shelf piece to help support the chimney bricks.

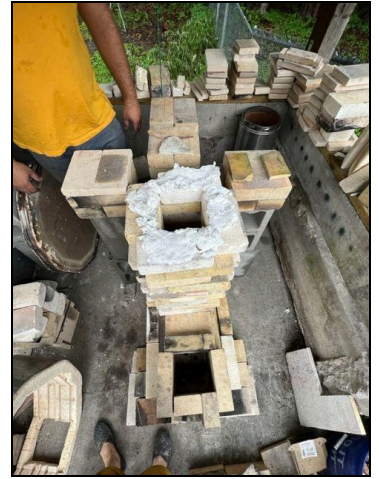

Down Draft Brick-Efficient Kiln

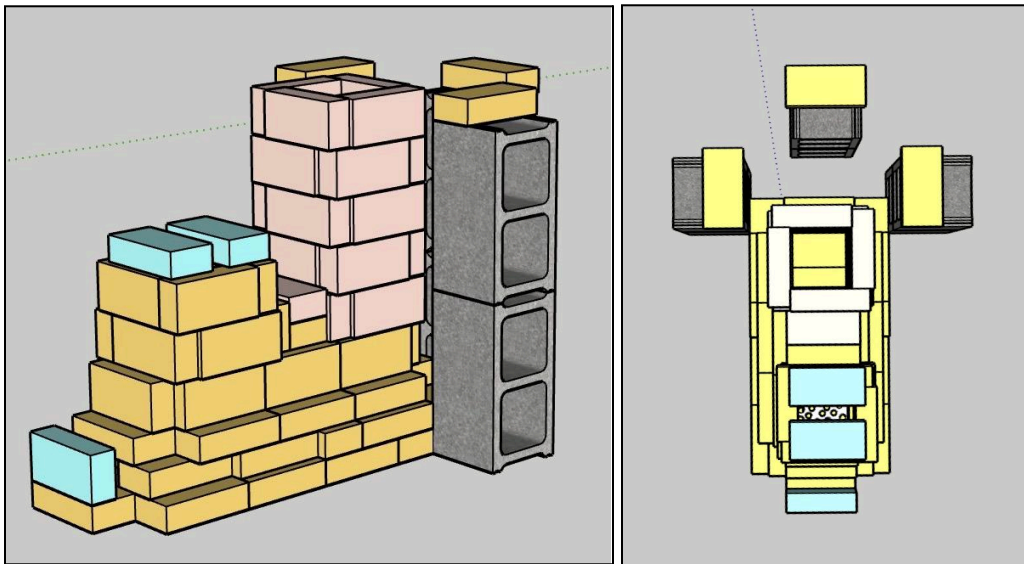

You'll need 6 cinder blocks. It's more stable to alternate the direction of the blocks like the photo on page 10. The footprint of the DDBE kiln is about 3' x 4'6".

Cross Draft Firing-Efficient Kiln

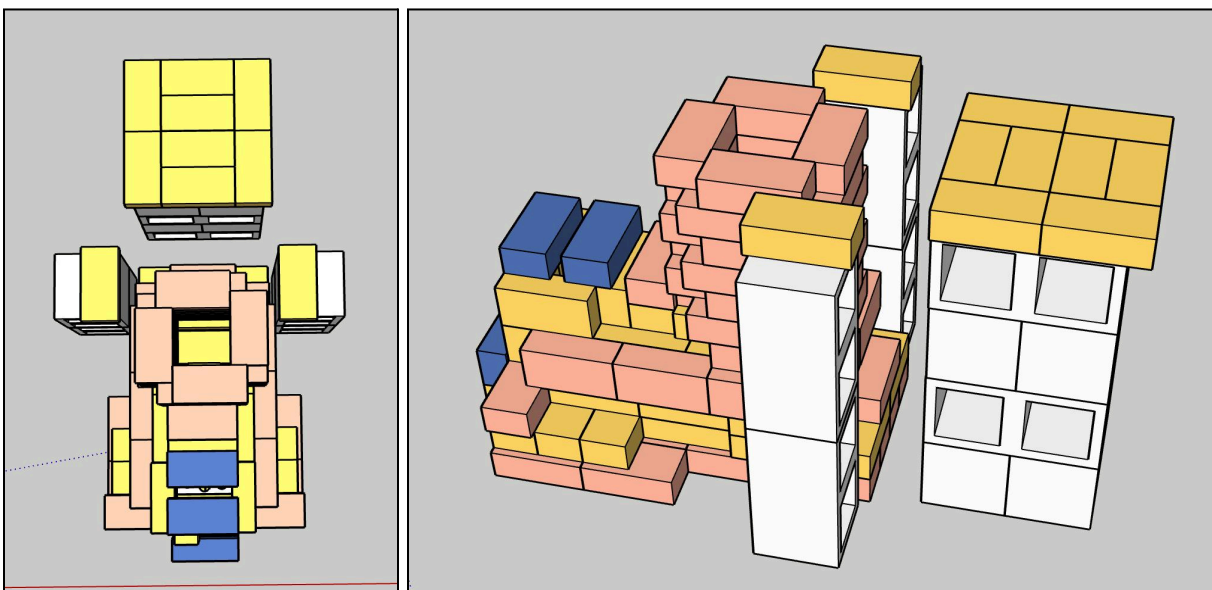

You will need 12 cinder blocks for the CDFE version of the rocket kiln. You may want to use a large shelf to help support the bricks below the chimney. The footprint of this version is about 3' x 5'3".

Cutting the Inlet Flue

A cardboard template cut to 7"x7" and set about 3" in from the edge of the bottom works well to mark your cuts. We gently cut the brick with a handsaw after drilling holes in each corner. You can use a jig saw, oscillating multitool, or sheet rock saw to cut through the soft brick. We selected an already crumbling section of the kiln floor to place our cut. We suggest lining it up with one of the "flat" sides. Consider adding a worm band around the bottom of the kiln to reinforce the bottom strapping. We have experienced that many of these antiquated bands fail during firing.



A permanent marker works well to trace onto bricks.

NOTE: If your kiln shell has an integrated bottom (like an old paragon kiln), be mindful of where the peep holes are located in reference to the inlet flue. We have found it helpful to have the peeps 1-2 sections away from the section adjacent to the heat riser. This allows for easy cone viewing. Cones should be placed IN the shelf stack, not at the heat riser; this improves the accuracy of the cones compared to the maturity of the wares.

Building the Internal Chimney and Cutting the Exit Flue for the DDBE kiln

The Downdraft Rocket Kiln borrows a lot from the TDI (Thermal Draft Induction) gas/soda kiln conversion plans. You will need some spare rectangular kiln shelves to create an internal chimney partition. The plans use 10"x20" kiln shelves, which also fit easily in the kiln to load work on if you can procure a handful of them.

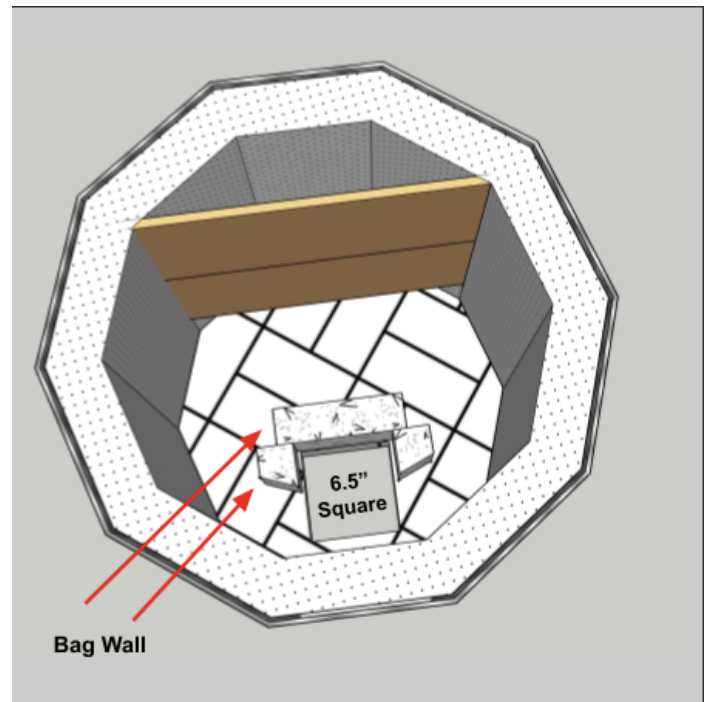
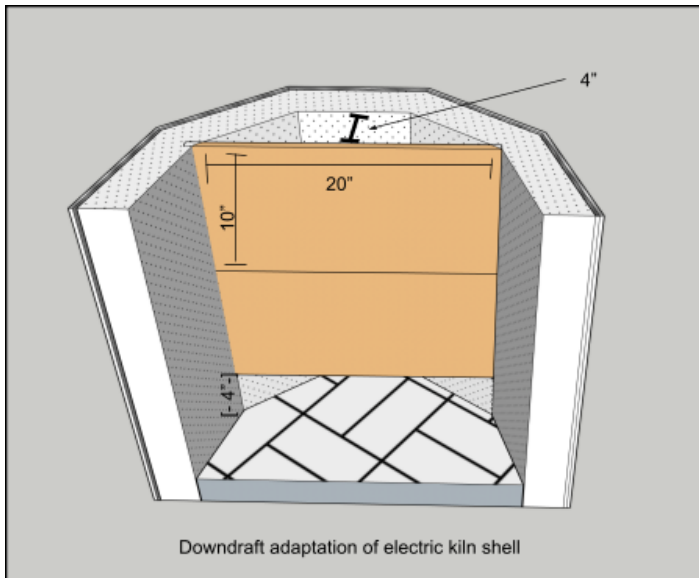

*The above rendering should have a 7"x7" square.

Note: Just use pots as a bag wall, No need to use brick.

The opening between the kiln lid and chimney is 40 sq. in., not 50 like the other parts of the kiln. This creates a bit of a venturi effect and helps induce the natural draft of the kiln.

You can use a pair of 4" kiln posts as a support for the internal chimney. Fireclay wadding was used to seal the sides of the chimney.

The size and placement of the bag wall will need to be adjusted based on the kiln shelves you're using and the height of the wares being fired. We've found that placing work tight to the inlet flue will act like a bagwall and allow for more pieces to be fired— so **no brick bagwall needed** at all, just stack ware right on the floor of the kiln.

Make another template that is 4"x10" to trace an exit flue in the lid of the kiln (see pictures in damper section).

Leave ~2-4" of space around the exit flue when loading. This is usually a cold spot and is needed for proper draft.



Cutting the Exit Flue for the CDFE Kiln



A 7"x7" hole should be cut in one of the sides of the bottom most section of the kiln body. You may need an angle grinder or dremel to cut through the metal of the kiln. Leave a strip of the metal intact on the top and bottom of the hole. Any places with crumbled brick were filled in with Kaowool or replacement brick.

In the below image you can see how the heat riser and flue openings are opposite of each other.

If building under an awning, use a plumb bob to determine where to locate where ideally the chimney should go through the roof .



Cut the metal jacket back about 1" from the opening if possible so it won't get exposed to heat and melt.

The Damper and Chimney

Dampers

All rocket kilns should incorporate a damper. This can be made from brick or cut-to-size kiln shelves. We have included documentation of 4 different damper options to better help you problem-solve based on your available materials.

DDBE dampers

Brick Damper (easier)

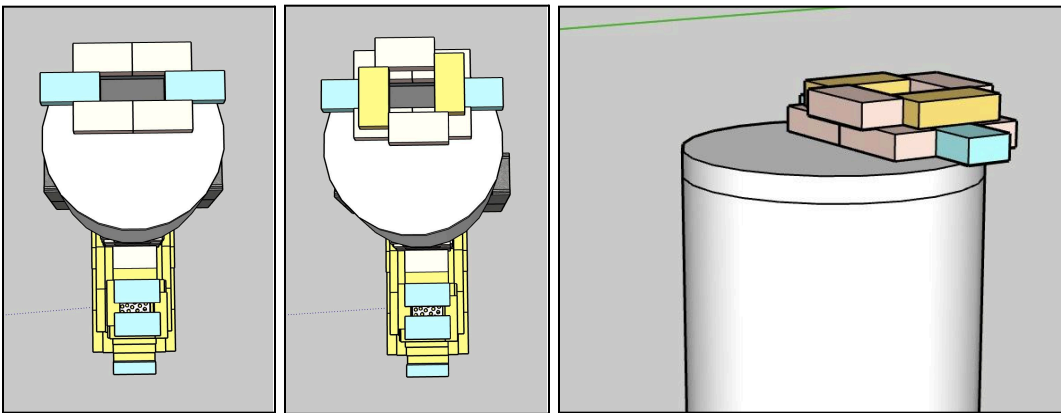

Carve markings on the damper softbricks (blue bricks) so you know where fully open and half-open are. This damper will be completely pushed in (hard to pull back out) when it's fully closed. Hard bricks are used to span the dampers to better support the chimney.

We have noted that about half-closed is a good starting point if you are trying to fire in reduction. We have successfully reduced these kilns without generating smoke. You may also need to close the secondary air to induce reduction. When you look through a kiln peep, a cloudy atmosphere is indicative of reduction.

Shelf Damper (better)



Cut a Kiln shelf to slide in and out of the opening. Add markings before firing to note where open, closed, and halfway are on the damper.

CDFE Kiln Dampers

Chimney Support and Exit Flue Transition

The crossdraft variations of the Rocket Kiln need a transition section from the exit flue in the kiln body to the base of the chimney. There are a number of ways to do this, but the chimney needs to be separated by at least one brick thickness of insulation from the kiln body (closer causes issues with the metal shells around the kiln body).

Below is a step-by-step series of renderings showing one option for chimney/damper support. Additional photos of actual dampers follow. These renderings pick up immediately after those on the bottom of page 16. Overlapping bricks should be rabbeted (notched) accordingly, and maintaining the 7"x7" opening or appropriate (~50 sq. in in all of our renderings) cross-sectional area.

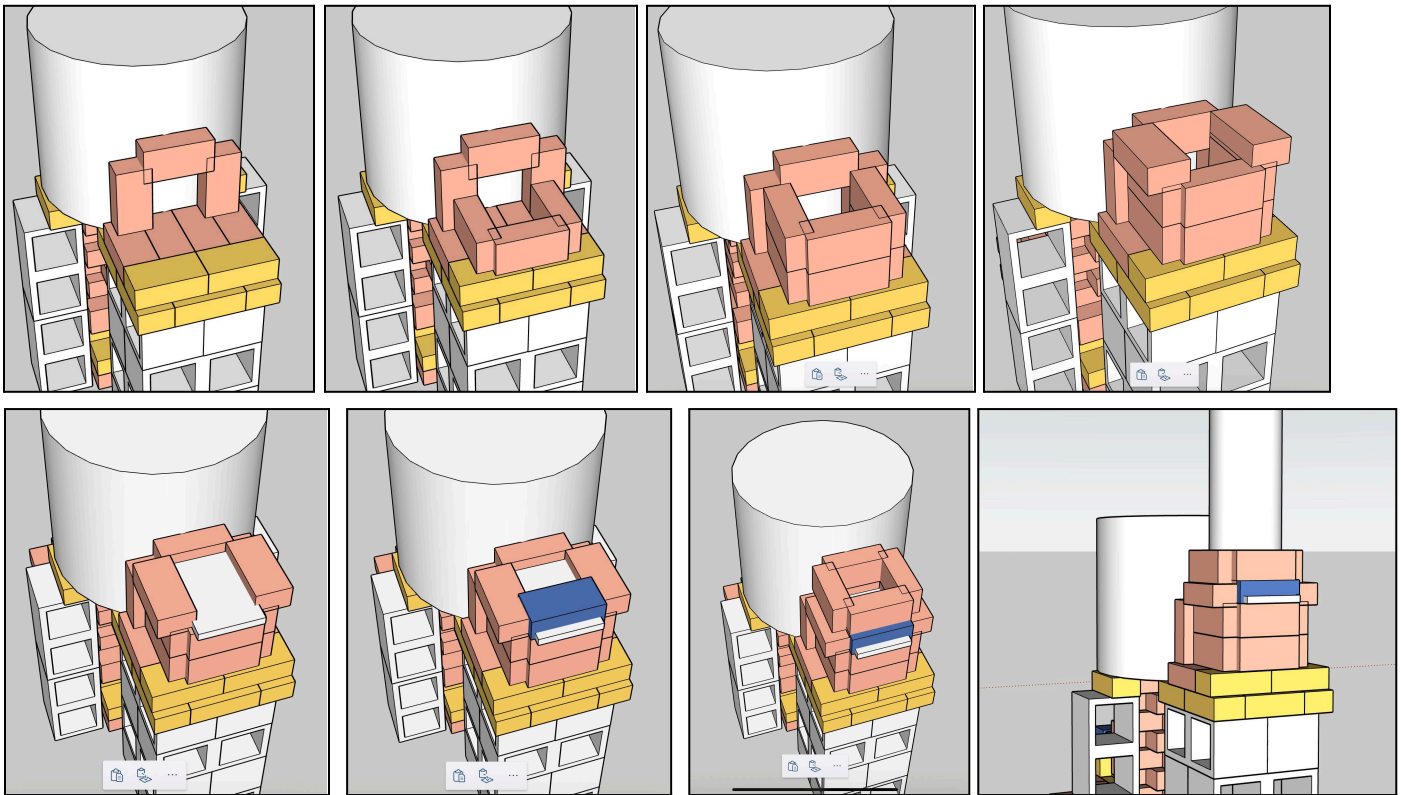

Chimney/Damper Support Details

These photos show how the kiln bricks are rabbeted (cut a “bird’s mouth” notch) to support the brick over the exit flue transition. These bricks can be oriented like those in either of the photos, as long as there is a sufficient fiber gasket and enough pressure (from worm-band or other means) holding the bricks in place.



Below you can see how the support bricks are rabbeted to accommodate the damper. Hardbricks are being used here because it is a wear point, if you don't have a wet saw, using soft brick is acceptable. Generally, any unsupported span should use a hardbrick if it is loadbearing (like supporting a chimney or the heat riser).



CDFE Dampers

The dampers for the crossdraft kiln bear much resemblance to traditional wood kiln or gas kiln dampers. You may need extra support for when the damper is fully open (pictured right).



The above example uses a 6.75" x 10" damper. The photos show how the bricks in the renderings can be cut to create a channel for the damper. A piece of soft brick should be cut to block the opening directly above the damper (blue brick in renderings); this prevents cold air from cooling the chimney and slowing the draft.

Additional Examples of Dampers:

The middle photo shows a suspended vertical damper. There was an added tunnel to the chimney to move it out from a roof eave. The vertical damper is suspended on cable, ran through 2 pulleys, and then tied off, with a small cord, to a cleat, mounted out of the way. The right image shows how a soft brick is notched to block the air from coming in above the damper. This brick moves when the damper is pulled in and out, but is easily wedged back into place.

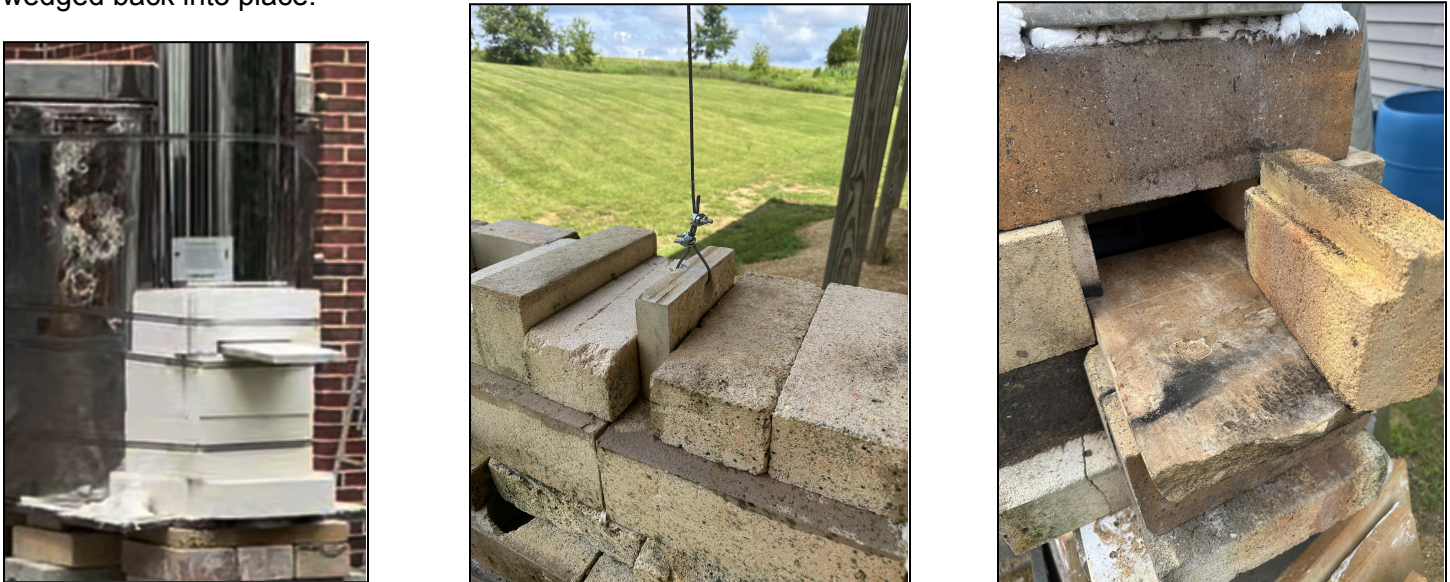

Chimneys

Once the damper is in place, the chimneys for the crossdraft and downdraft kilns follow the same basic principles: they need to be insulated, they need to be the proper diameter (8" ID is standard), and they need to be tall enough.

Chimney Insulation

Double-wall insulated and triple-wall stove pipes have worked well for these kilns. While they don't last forever, especially when fired in heavy reduction, if the flame is kept in the kiln and out of the chimney, you can expect to get many firings out of them. Be sure to use kaowool to form a gasket between the brick supports and chimney base.

The photo to the right shows a triple wall stove pipe on a DDBE rocket kiln. You can see the kaowool insulation and guy wires used to stabilize the chimney on windy days. Galvanized wire is cheap and works well for this.

If you have a permanent kiln location, you may choose to build the chimney out of soft brick; this also works well.

Chimney Diameter

As discussed on page 5, the proportions of the J-Tube and Chimney are important to the effective firing of a Rocket Kiln. The Chimney, Flues, and J-Tube should (generally) have the same cross-sectional area. While small kilns have been fired with 6" ID (Internal Diameter) stove pipe chimneys, 8" ID Stove pipe works better for the size of most kiln conversions, is readily available, and is proportional to standard brick sizes. The 8" ID chimney has a cross-sectional area of ~ 50 sq. in. (Area of a Circle = $\pi \cdot r^2 = 3.14 \cdot 4^2 = 50.24$ sq. in.); this is where the 7" x 7" J-tube and flue proportions are derived ($7 \times 7 = 49$ sq. in.). If you use a different size chimney, plan accordingly with the rest of your kiln build.

Chimney Height

If your chimney is too short, your kiln will lack draft, struggle to reach temperature and probably fire unevenly. Chimney height may need to be adjusted after your first firing by adding or removing some support bricks or altering the stove pipe length. The calculation (guideline) for chimney height comes from *The Kiln Book* by Fred Olsen and is outlined by kiln design principle 5:

"For natural-draft kilns there should be 3ft of chimney to every 1ft of downward pull (dp), plus 1ft of chimney to every 3ft of horizontal pull (hp)." (p79, 4th ed.)

From this we get the equation: Chimney Height = $(3 \cdot dp) + (hp/3)$

The height of the chimney is calculated from the bottom of the firebox (ground level). Therefore, the heat riser is counted as part of the chimney height. An illustration and example calculation are shown on the following page. A 3-4' section of stove pipe above a downdraft kiln, or a 4-6' section of stove pipe on a crossdraft kiln, typically gets you close to the right height. However, we have found that a total height of 8-10 feet from the ground works well. If you have a chance to fire the same kiln with different height chimneys, you can determine what height is "sufficient" and what is "optimal".



Downdraft + Ratchet Kiln

- ▣: Downward Pull (dp)
- ▣: horizontal Pull (hp)
- ▣: Chimney height
- ▣: Stove Pipe length

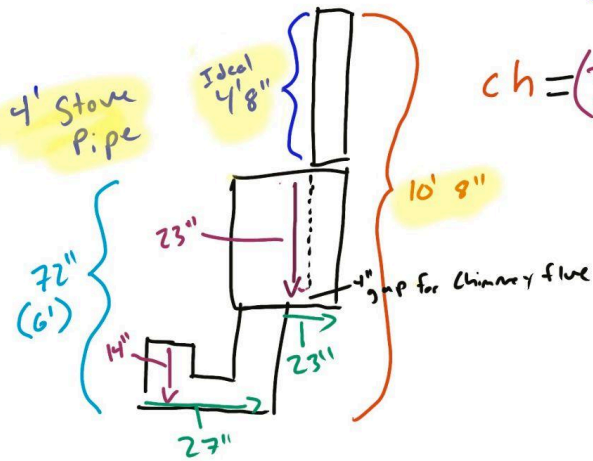

$$ch = (3 \times dp) + (hp \div 3)$$

$$(3 \times 37") + (50" \div 3) =$$

$$111" + 16.7" = 128"$$

OR
10' 8"

Crossdraft Ratchet Kiln

- * Assuming 1027 kiln body & 7x7" J-Tube w/ 8" ID chimney.
- * Not drawn to scale.

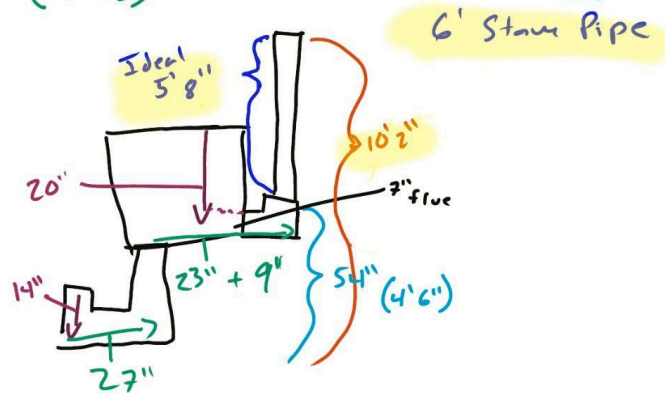

$$(3 \times 34) + (59" \div 3) =$$

$$102" + 19.7" = 122"$$

OR
10' 2"



Here you can see the added 8" (inside diameter) insulated stove pipe. We are able to fire to cone 10 in 3-4 hours with a 3' or 4' stove pipe. If you have a larger kiln body a 4' pipe or added brick layers may be necessary. This chimney could also be constructed from soft brick as the insulation increases the draw. Band the chimney to the kiln, or use guy wires, so it will not be affected by wind. **Lisa and Andrew have had success with chimneys**



terminating about 8'-9' off the ground. This is shorter than the calculation, but seems to provide sufficient draft.

Firing the Rocket Kiln: Tips, Tricks, and Best Practices

Adjusting the Air and Stoking the Kiln

Soft bricks help close off the primary air opening at the top of the firebox and dry kindling (the thinner, the better– thumb width is ideal) is fed in from the top. Closing off some primary air encourages more air to come in underneath the burning wood at the secondary air entrance. The wood is “self-feeding” from the fire pulled sideways at the bottom. If wood is damp, it can very effectively be dried in the crook of the J-tube on top of the burn tunnel, or on top of the warm kiln. We have noticed that this style kiln fires poorly with hardwoods, scrap pallets and softwoods like pine are the best. Hardwoods create larger coal beds which can clog the grate and burn tunnel.

There are also two hard bricks in front of the secondary air. The bottom one is just a riser. The second one should be adjusted to keep the kiln firing efficiently. If flame is IN THE CHIMNEY, the stove pipe will superheat and glow, this is bad for the chimney pipe and means you are stoking too heavily or not enough primary/secondary air is coming into the rocket kiln. Firing in a neutral/efficient manner may require you to change how you think about firing a wood or gas kiln, as this kiln is designed to maximize efficiency, not atmospheric effects.

Soda Effects

We have fired these kilns with sprayed soda to create flashing. Using one of the peep hole ports or pyrometer ports worked well. Alternatively, one can place cups of a soda mix in little cups next to/between/under pottery pieces in the kiln. This will give a slower, curvier flash on clays and flashing slips. Gail Nichols' recipe works well:

Whiting	50%
Light Soda Ash	20% (Calcine soda ash at 700°F)
Baking Soda	30%

Mix with an additional %60 water, by weight, allow to set (This is Exothermic and large batches can get hot!) This mixture and the soda ash are CAUSTIC, wear gloves!

(p.8, *Soda, Clay and Fire* by Gail Nichols)

Place the cups as close to the pieces as possible, or wad pieces on top of them!